

VIEW A
SCALE 1 : 8

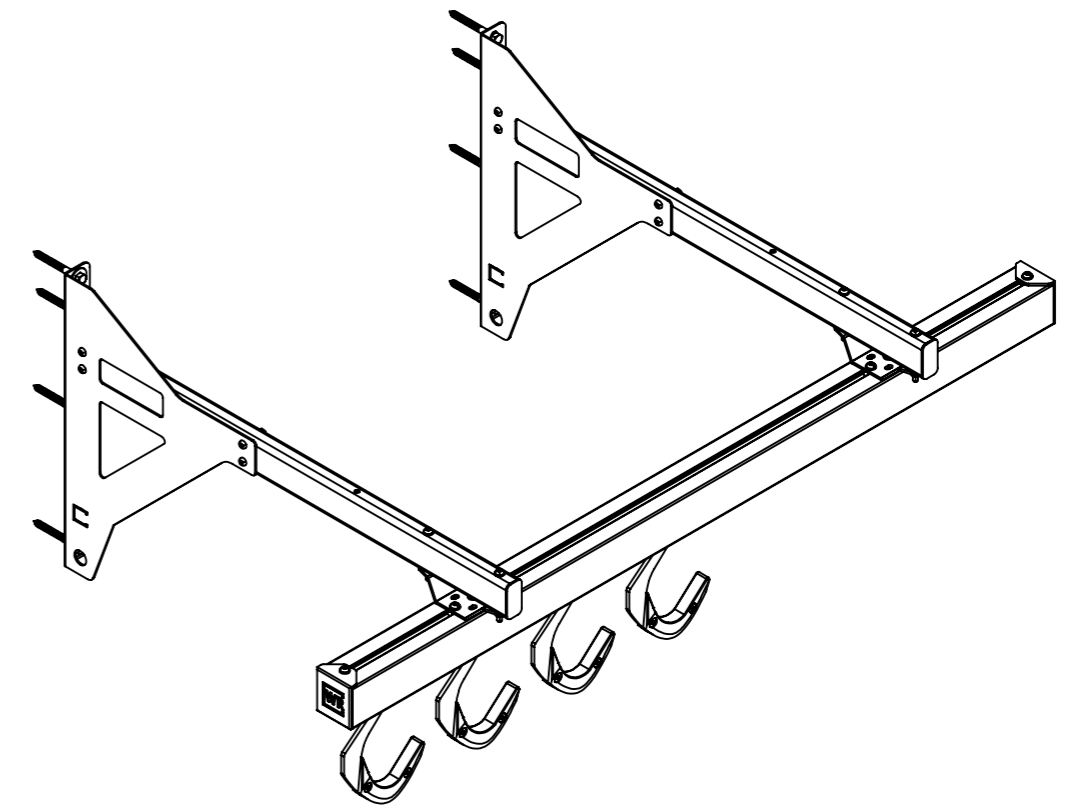

1	Wall System				---	01	HDN	---				
Item	Designation				Material	Size in mm	Qty	Mass	Plating/Coating			
	Surface Roughness Ra μ m		Angular 30'						Plating/Coating			
	N9	6.3	> 900	2.0					Area 1758820.21 mm ²			
	N8	3.2	600	900	1.0				Scale 2:1			
	N7	1.6	300	600	0.5				Dim.	Tol.	Station	Sub Assy
	N6	0.8	150	300	0.3				mm	mm	00	A00
	N5	0.4	50	150	0.2				Drawn Checked Approved			
	N4	0.2	0.5	50	0.1			Sig. NB NB BH				
Symbol	Grade	Value	Over	Upto	Value (\pm)	Rev No	Alterations		Date	Date 20-01-2024 20-01-2024 20-01-2024		
				Wheelsonrail - Wall Mntg Storage Sytem				Dwg No WR-WS-R0		R0 REV		
Wheelsonrail, India								Sheet 1 OF 2				

Copy right of this drawing is owned and retained by Wheelsonrail. Unauthorised use not permissible and a cognizable offence in the absence of permission from Wheelsonrail.

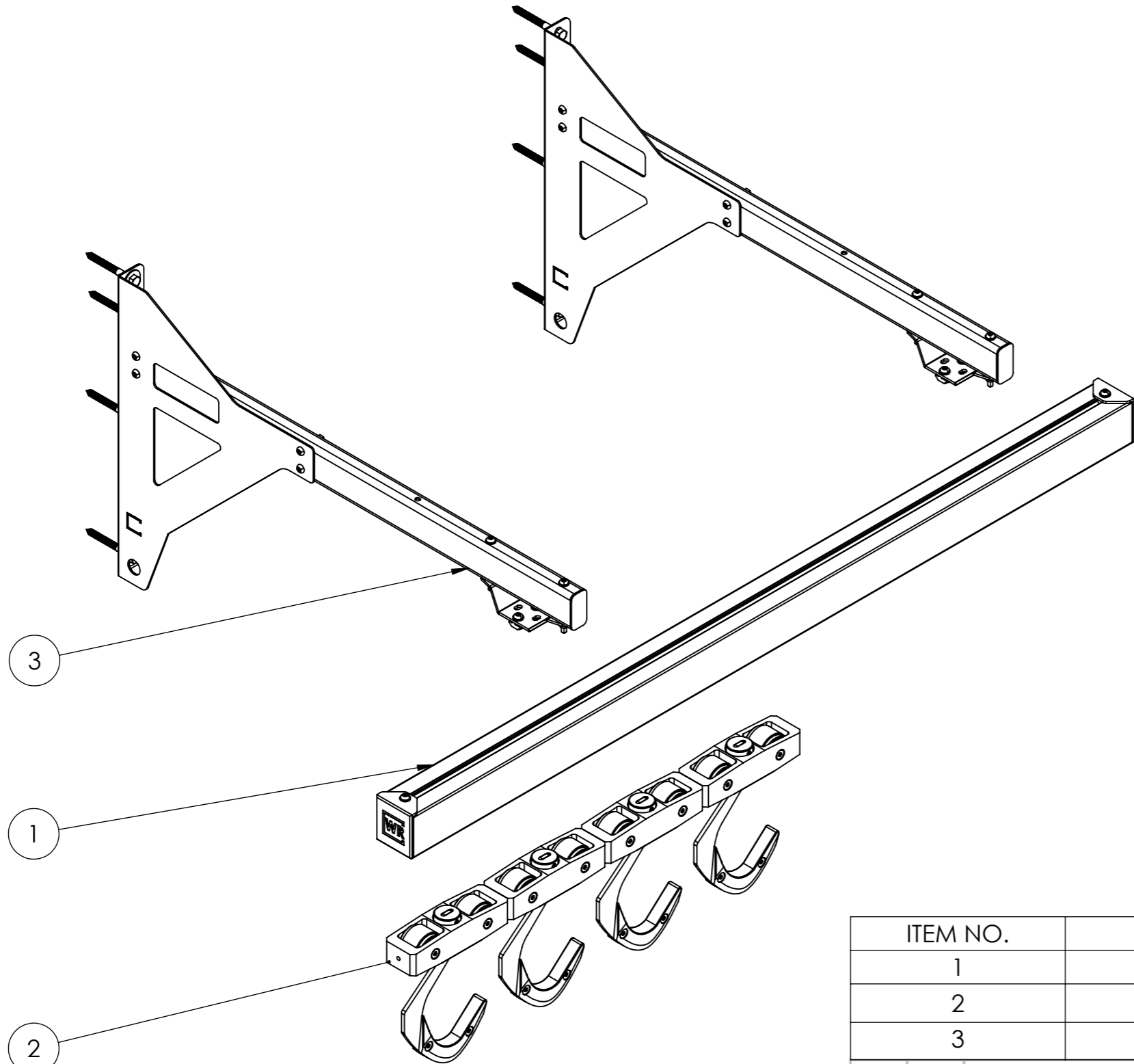

ITEM NO.	DESCRIPTION	QTY.
1	Bikerail Unit	1
2	Bike Hook	4
3	Wall Mounting Bracket Assembly	2

1	Wall System				---	01	HDN	---					
Item	Designation				Material	Size in mm	Qty	Mass	Plating/Coating				
	Surface Roughness Ra μ m		Angular 30'						Plating/Coating				
	N9	6.3	> 900	2.0					Area 1758820.21 mm ²				
	N8	3.2	600	900					1.0	Scale 2:1			
	N7	1.6	300	600					0.5	Dim. Tol. Station Sub Assy			
	N6	0.8	150	300					0.3	mm mm 00 A00			
	N5	0.4	50	150					0.2	Drawn Checked Approved			
	General Tolerance		Over	Upto	Value (\pm)	Rev No	Alterations		Date	Sig. NB NB BH			
	N4	0.2	0.5	50	0.1		Date		20-01-2024	20-01-2024	20-01-2024		
		Wheelsonrail - Wall Mntg Storage Sytem				Dwg No WR-WS-R0		R0 REV					
Wheelsonrail, India								Sheet 2 OF 2					

Copy right of this drawing is owned and retained by Wheelsonrail. Unauthorised use not permissible and a cognizable offence in the absence of permission from Wheelsonrail.